

Ultimate Electrostatics Assignment

Key Formulae:

$$F = k \frac{Q_1 Q_2}{r^2}$$

$$E = \frac{F}{Q}$$

$$E = \frac{kQ}{r^2}$$

$$\Delta V = \frac{\Delta E_p}{Q}$$

$$E = \frac{\Delta V}{d}$$

$$E_p = k \frac{Q_1 Q_2}{r}$$

$$V = \frac{kQ}{r}$$

0108

1.

Which of the following best illustrates the electric field between parallel plates with opposite electric charges?

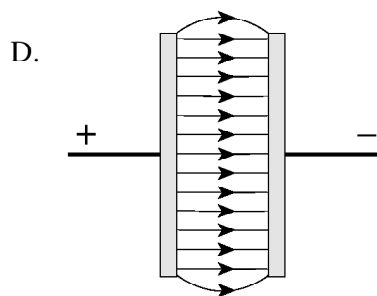
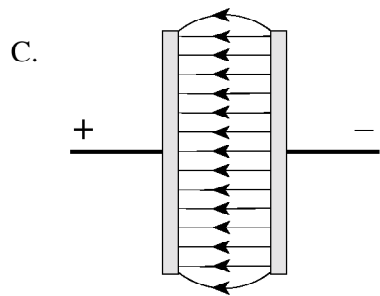
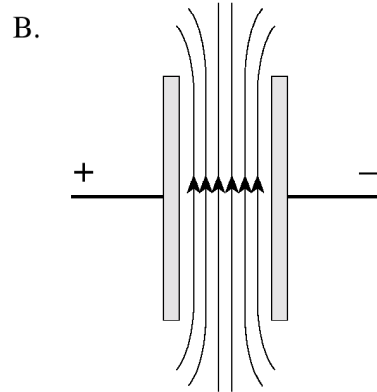
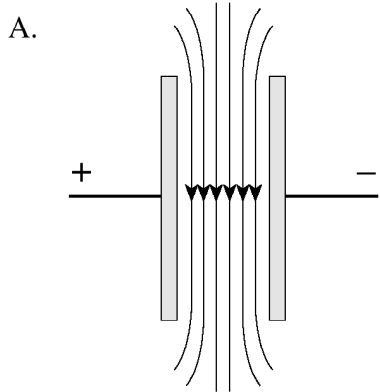

2.

The atomic nucleus of uranium contains 92 protons. What is the direction and magnitude of the electric field 2.5×10^{-10} m from this nucleus?

	DIRECTION OF ELECTRIC FIELD	MAGNITUDE OF ELECTRIC FIELD
A.	towards nucleus	5.3×10^2 N/C
B.	away from nucleus	5.3×10^2 N/C
C.	towards nucleus	2.1×10^{12} N/C
D.	away from nucleus	2.1×10^{12} N/C

3.

A 0.16 C charge is moved in an electric field from a point with a potential of 25 V to another point with a potential of 95 V. How much work was done to move this charge?

- A. 4.0 J
- B. 11 J
- C. 15 J
- D. 19 J

4.

A beam of electrons is directed to a region between oppositely charged parallel plates as shown in the diagram below.

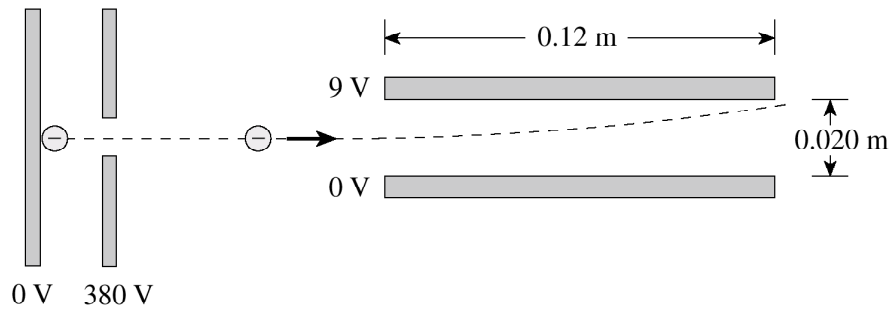

- a) The electron beam is produced by accelerating electrons through an electric potential difference of 380 V. What is the speed of the electrons as they leave the 380 V plate?
(3 marks)

- b) What is the electrostatic force on electrons in the region between the horizontal plates when they are connected to a 9.0 V potential difference? **(4 marks)**

0106

5.

A positively charged oil droplet is in a vertical electric field.

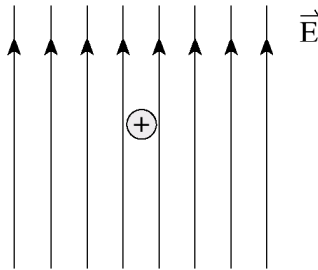

Which of the following is a correctly labelled free-body diagram showing the forces acting on the oil droplet?

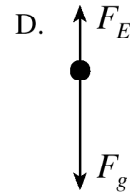
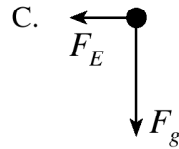
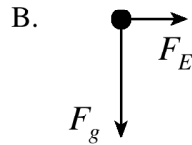
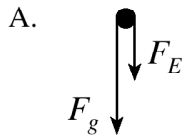

6.

What are the magnitude and direction of the electric field between the plates in the situation shown below?

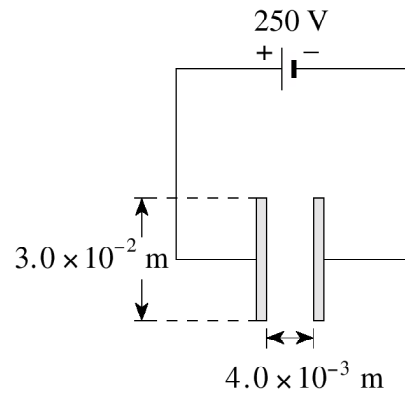

	DIRECTION OF FIELD	MAGNITUDE OF FIELD (V/m)
A.	left	8.3×10^3
B.	right	8.3×10^3
C.	left	6.3×10^4
D.	right	6.3×10^4

7.

Electric charges Q_1 and Q_2 are arranged as shown in the diagram below.

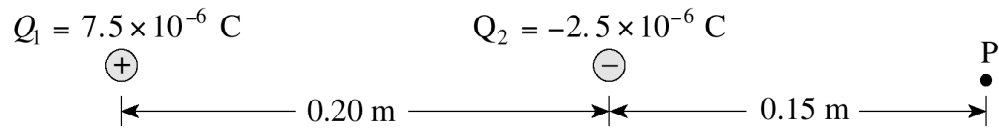

What is the electric potential at point P?

(7 marks)

8.

A student decides to investigate how electric field varies along the line connecting two positive point charges. Charge Q_2 is greater than charge Q_1 .



Using principles of physics, describe the electric field along the line from Q_1 to Q_2 . **(4 marks)**

0101

9.

Which of the following best describes how electric potential varies with distance in the region around a point charge?

- A. $V \propto r$
- B. $V \propto \frac{1}{r}$
- C. $V \propto r^2$
- D. $V \propto \frac{1}{r^2}$

10.

Three **identical** positive electric charges are fixed as shown in the diagram below.

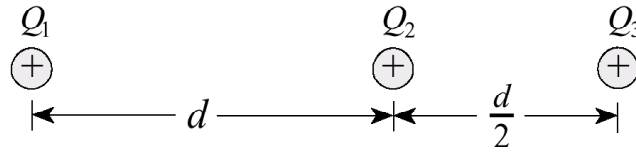

What is the direction of the net electric force on Q_2 due to Q_1 and Q_3 ?

- A. to the left
- B. to the right
- C. the net force is zero
- D. cannot be determined

11.

In an experiment, a positively charged oil droplet weighing 6.5×10^{-15} N is held stationary by a vertical electric field as shown in the diagram.

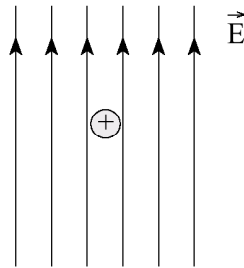

If the electric field strength is 5.3×10^3 N/C, what is the charge on the oil droplet?

- A. 1.2×10^{-18} C
- B. 3.4×10^{-11} C
- C. 4.1×10^4 C
- D. 8.2×10^{17} C

12.

Electric charges are arranged as shown in the diagram below.

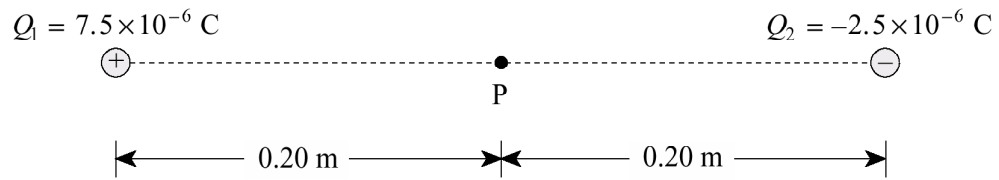

What is the electric field (magnitude and direction) at point P midway between the charges?
(7 marks)

0008

13.

The electric field is uniform between

- A. two positive point charges.
- B. two negative point charges.
- C. two opposite point charges.
- D. two oppositely charged parallel plates.

14.

What is the magnitude and direction of the electric field at point P due to the two fixed charges?

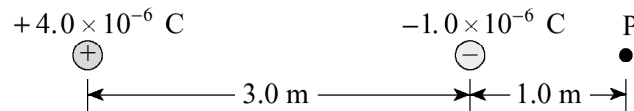

ELECTRIC FIELD AT POINT P	
MAGNITUDE	DIRECTION
A. 6 800 N/C	Right
B. 6 800 N/C	Left
C. 11 000 N/C	Right
D. 11 000 N/C	Left

15.

A proton with kinetic energy of 2.1×10^{-17} J is moving into a region of charged parallel plates. The proton will be stopped momentarily in what region?

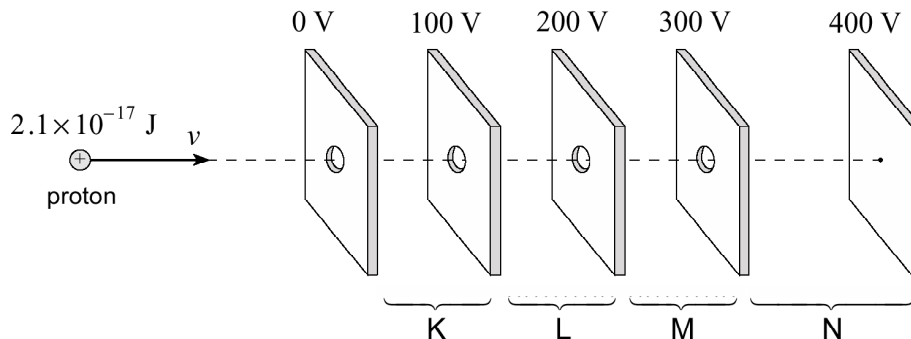

- A. Region K
- B. Region L
- C. Region M
- D. Region N

16.

A proton, initially at rest at point X, will have what speed at point Y?

(7 marks)



0006

17.

An electron in the electric field has an electric force acting on it in what direction?

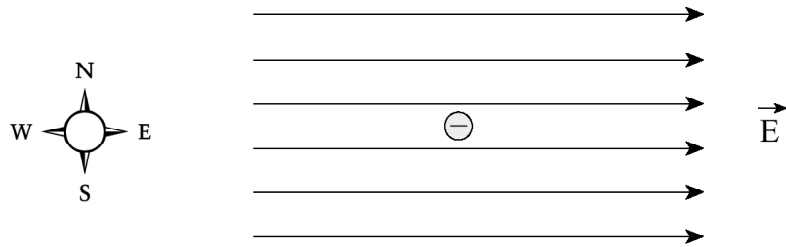

- A. North
- B. South
- C. East
- D. West

18.

What is the electric potential at point P due to the two fixed charges as shown?

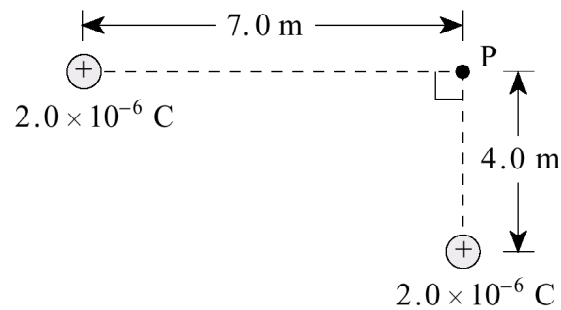

- A. 1 200 V
- B. 1 500 V
- C. 5 200 V
- D. 7 100 V

19.

A moving proton has 6.4×10^{-16} J of kinetic energy. The proton is accelerated by a potential difference of 5 000 V between parallel plates.

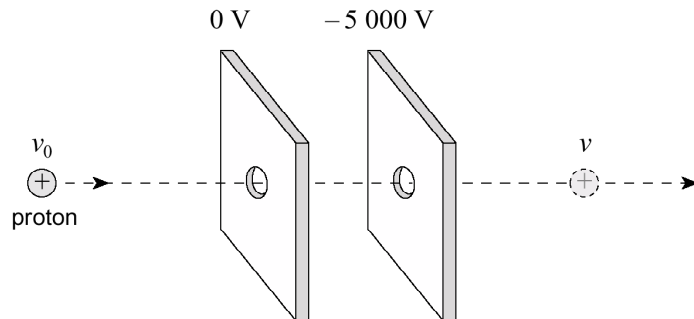

The proton emerges from the parallel plates with what speed?

- A. 8.8×10^5 m/s
- B. 9.8×10^5 m/s
- C. 1.3×10^6 m/s
- D. 1.8×10^6 m/s

20.

a) How much work is done in moving an electron from point X to point Y? **(5 marks)**

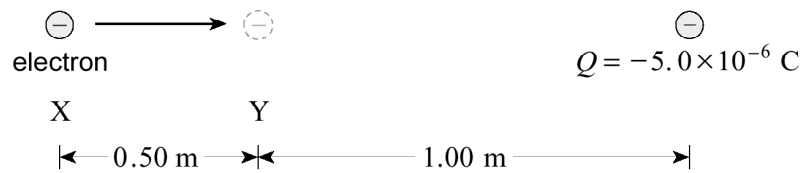

b) What is the potential difference between point X and point Y?

(2 marks)

0001

21.

Which of the following diagrams shows the electric field between two equal but opposite charges?

A.

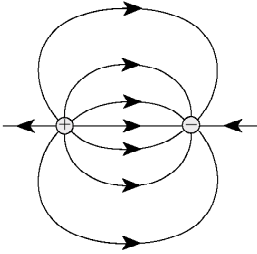

B.

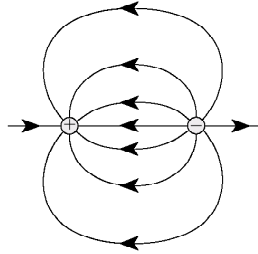

C.

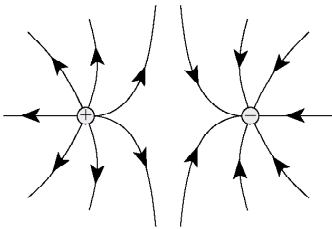

D.

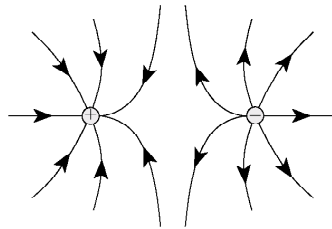

22.

A proton initially at rest is accelerated between parallel plates through a potential difference of 700 V.

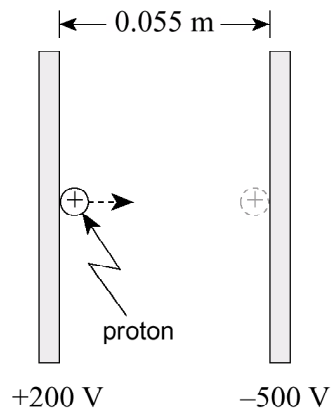

What is the maximum speed reached by the proton?

- A. 8.6×10^4 m/s
- B. 3.1×10^5 m/s
- C. 3.7×10^5 m/s
- D. 1.6×10^6 m/s

23.

What are the magnitudes of the electric field and the electric potential at point P midway between the two fixed charges?

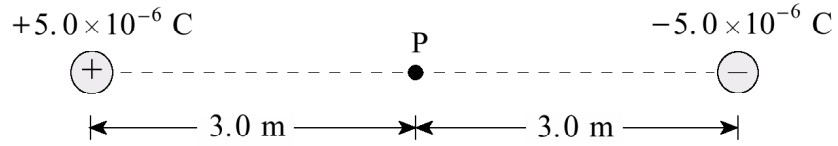

	MAGNITUDE OF ELECTRIC FIELD	ELECTRIC POTENTIAL
A.	0 N/C	0 V
B.	0 N/C	30 000 V
C.	10 000 N/C	0 V
D.	10 000 N/C	30 000 V

24.

A charge q of $30.0 \mu\text{C}$ is moved from point X to point Y.

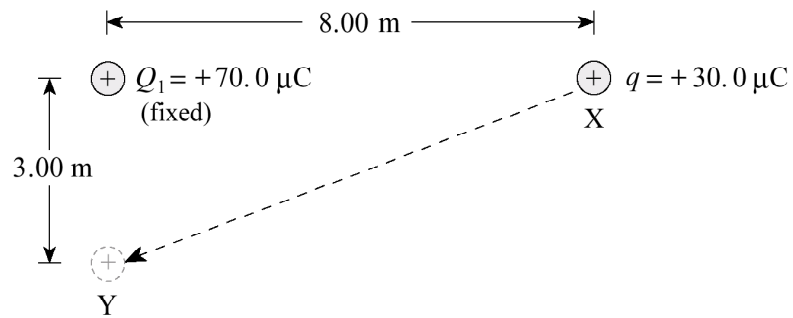

How much work is done on the $30.0 \mu\text{C}$ charge? ($1 \mu\text{C} = 1 \times 10^{-6} \text{ C}$)

(7 marks)

9908
25.

Which diagram shows the electric field near a negative point charge?

A.

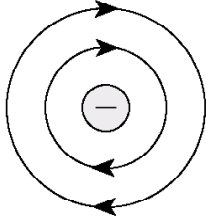

B.

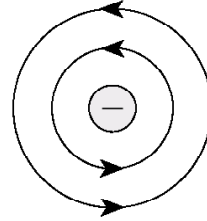

C.

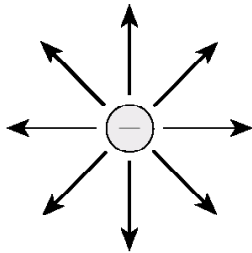

D.

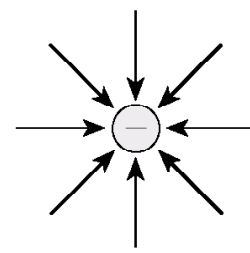

26.

Which pair of values will cause the greatest deflection of an electron beam in a cathode ray tube?

	ACCELERATING VOLTAGE	DEFLECTION (PLATE) VOLTAGE
A.	400 V	20 V
B.	400 V	40 V
C.	800 V	20 V
D.	800 V	40 V

27.

The magnitude of the net electric field at P in the diagram below is $5.0 \times 10^3 \text{ N/C}$.

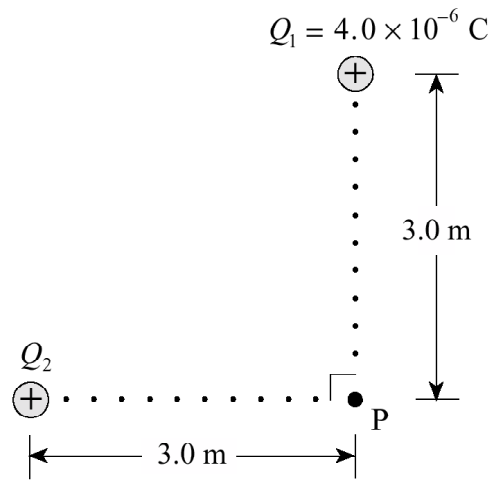

Find the magnitude of charge Q_2 .

- A. $1.0 \times 10^{-6} \text{ C}$
- B. $3.0 \times 10^{-6} \text{ C}$
- C. $6.4 \times 10^{-6} \text{ C}$
- D. $1.0 \times 10^{-5} \text{ C}$

28.

a) Find the electric potential at point A and at point B. (Note: $1.0 \mu\text{C}$ is $1.0 \times 10^{-6} \text{ C}$)

(3 marks)

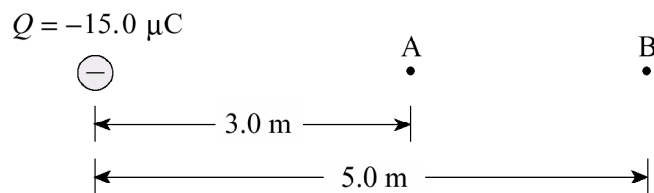

b) What is the potential difference between A and B?

(1 mark)

ANSWER:
b) potential difference: _____

c) 0.036 J of work must be done to move a charge q from A to B. Find the magnitude and polarity of this charge. (3 marks)

$Q = -15.0 \mu\text{C}$
 \ominus

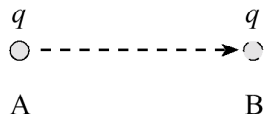

9906

29.

In a cathode ray tube,

- A. protons are accelerated from anode (positive) to cathode (negative).
- B. protons are accelerated from cathode (negative) to anode (positive).
- C. electrons are accelerated from anode (positive) to cathode (negative).
- D. electrons are accelerated from cathode (negative) to anode (positive).

30.

Charge Q_1 is located 5.0 m from charge Q_2 as shown.

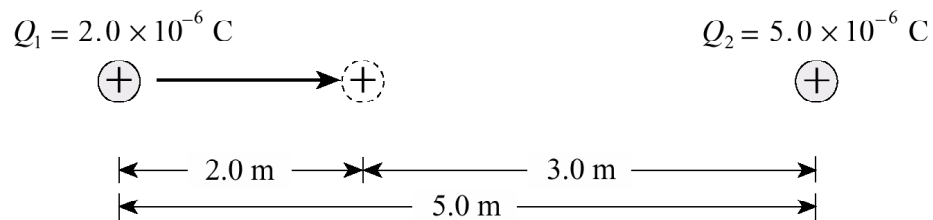

How much work must be done to move charge Q_1 2.0 m closer to charge Q_2 ?

- A. 7.2×10^{-3} J
- B. 1.1×10^{-2} J
- C. 1.2×10^{-2} J
- D. 2.0×10^{-2} J

31.

An electron orbits the nucleus of an atom with velocity v . If this electron were to orbit the same nucleus with twice the previous orbital radius, its orbital velocity would now be

- A. $\frac{v}{2}$
- B. $\frac{v}{\sqrt{2}}$
- C. v
- D. $2v$

32.

An electron passing between parallel plates 0.025 m apart experiences an upward electrostatic force of 5.1×10^{-16} N.

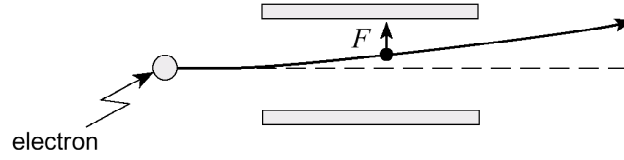

a) What is the magnitude of the electric field between the plates?

(3 marks)

b) What is the potential difference between the plates?

(2 marks)

c) On the diagram below draw in the connections to the power supply necessary for the electron to experience this upward force. (2 marks)

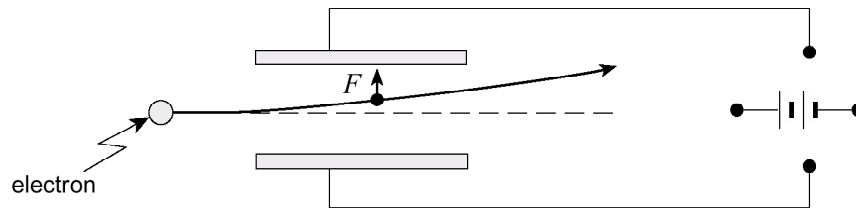

9901

33.

The diagram shows the electric field lines near two point charges, L and R. Identify the polarity of these point charges.

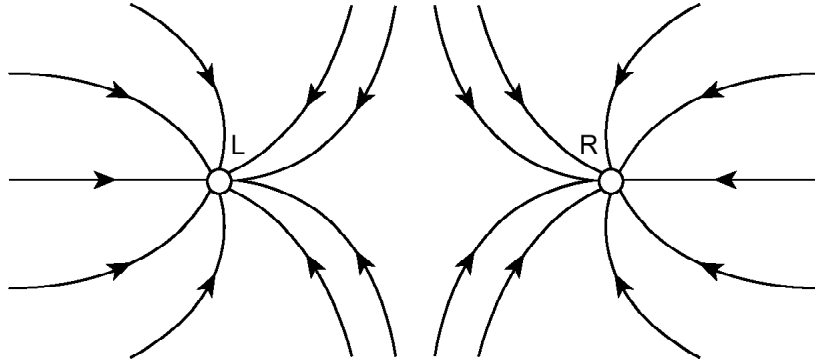

	POLARITY OF L	POLARITY OF R
A.	Negative	Negative
B.	Negative	Positive
C.	Positive	Negative
D.	Positive	Positive

34.

An electron orbits a nucleus which carries a charge of $+9.6 \times 10^{-19}$ C. If the electron's orbital radius is 2.0×10^{-10} m, what is its electric potential energy?

- A. -6.9×10^{-18} J
- B. -3.5×10^{-8} J
- C. 43 J
- D. 2.2×10^{11} J

35.

Two charges are positioned as shown in the diagram below.

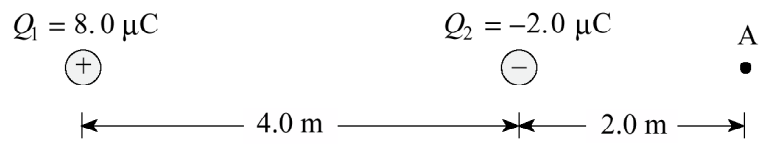

- a) Find the magnitude and direction of the electric field at A. (Note: $1.0 \mu\text{C} = 1.0 \times 10^{-6} \text{ C}$)
(4 marks)

- b) A charge placed at A experiences a force of 4.0×10^{-3} N towards the right. What are the magnitude and polarity of this charge? **(3 marks)**

9808

36.

Which of the following correctly describes the polarity of the charges X and Y?

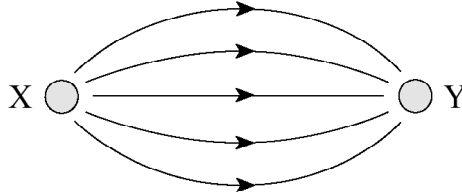

	POLARITY OF X	POLARITY OF Y
A.	Positive	Negative
B.	Positive	Positive
C.	Negative	Negative
D.	Negative	Positive

37.

Three positive charges are fixed as shown in the diagram below.



Calculate the net electric force on Q_2 due to Q_1 and Q_3 .

	MAGNITUDE OF FORCE	DIRECTION OF FORCE
A.	3.1 N	Left
B.	3.1 N	Right
C.	5.9 N	Left
D.	5.9 N	Right

38.

A cathode ray tube beam deflects to the location as shown in Diagram I when a certain voltage is applied to the deflecting plates.

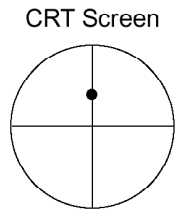

Diagram I

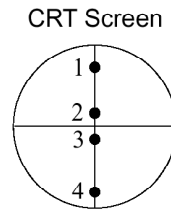

Diagram II

The connections to the deflecting plates are then **reversed** and the deflecting voltage is **reduced**. Which location in Diagram II best represents the new beam position?

- A. Location 1
- B. Location 2
- C. Location 3
- D. Location 4

39.

An electron moving at 7.5×10^6 m/s enters an electric field between parallel plates by passing through a small hole in one of the plates.

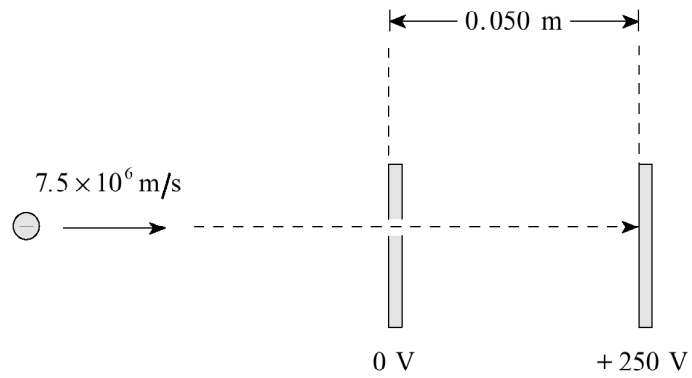

What is the impact speed of the electron on the second plate?

(7 marks)

9806

40.

Which of the following best represents the electric field between oppositely charged parallel plates?

A.

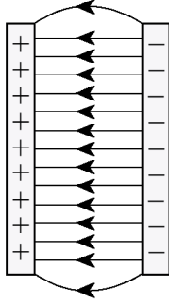

B.

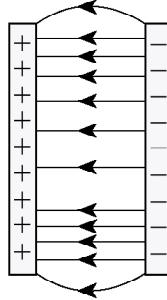

C.

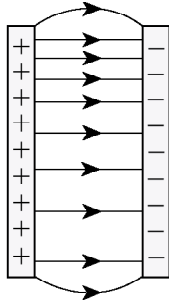

D.

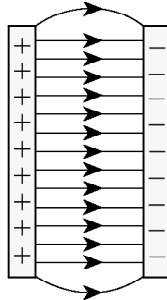

41.

Three point charges of equal magnitude but opposite sign are arranged as shown in the diagram below.

$\oplus Q_3$

\oplus
 Q_1

\ominus
 Q_2

Which of the diagrams below best represents the electric forces acting on Q_3 due to the other two charges?

A.

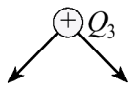

B.

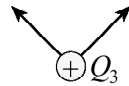

C.

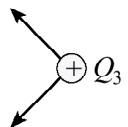

D.

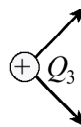

43.

Two point charges Q_1 and Q_2 are arranged as shown in the diagram below.

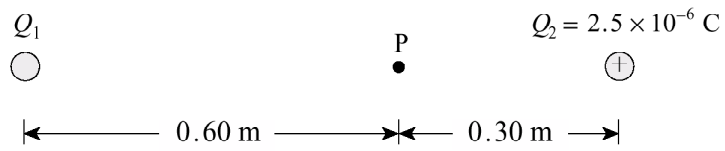

The electric potential at point P due to these charges is found to be $1.9 \times 10^5 \text{ V}$. What are the magnitude and sign of charge Q_1 ? **(7 marks)**

9801

44.

A cathode ray tube is adjusted so as to deflect the beam as shown.

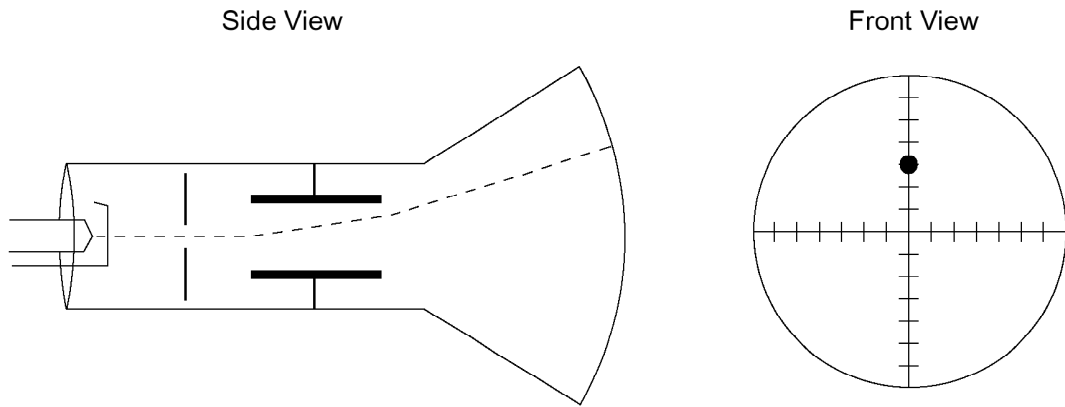

If the deflecting voltage is held constant and the accelerating voltage is then **decreased**, which diagram displays the new deflection?

A.

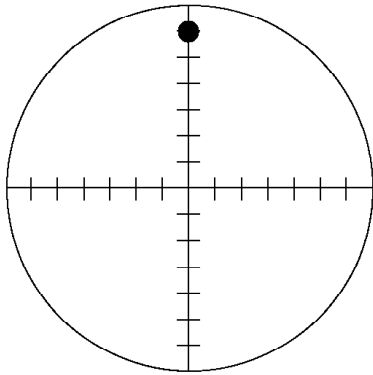

B.

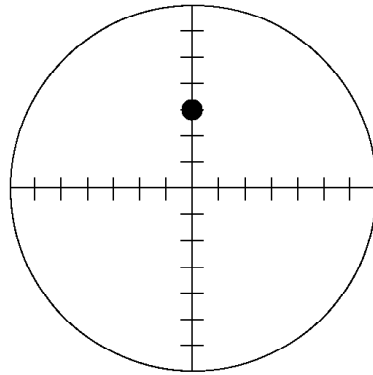

C.

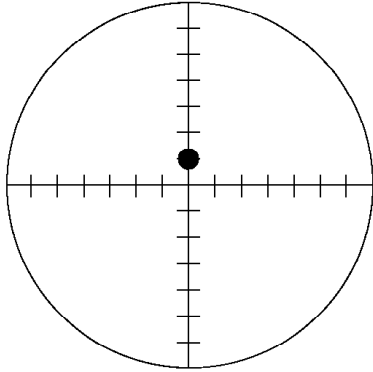

D.

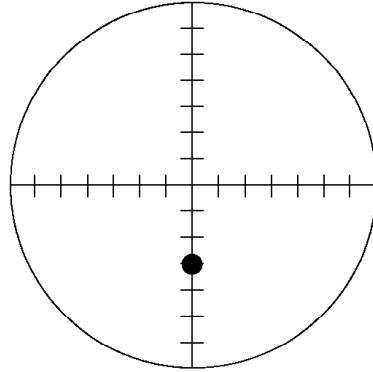

45.

What is the change in **kinetic energy** of an electron that moves from the negative plate to the positive plate in the situation shown below?

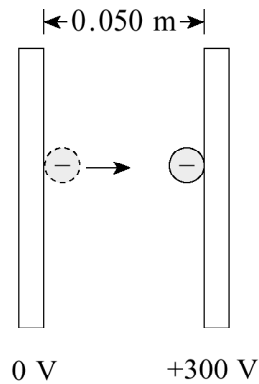

- A. A gain of 4.8×10^{-17} J
- B. A loss of 4.8×10^{-17} J
- C. A gain of 9.6×10^{-16} J
- D. A loss of 9.6×10^{-16} J

46.

Two 2.0×10^{-6} C charges are positioned as shown in the diagram below.

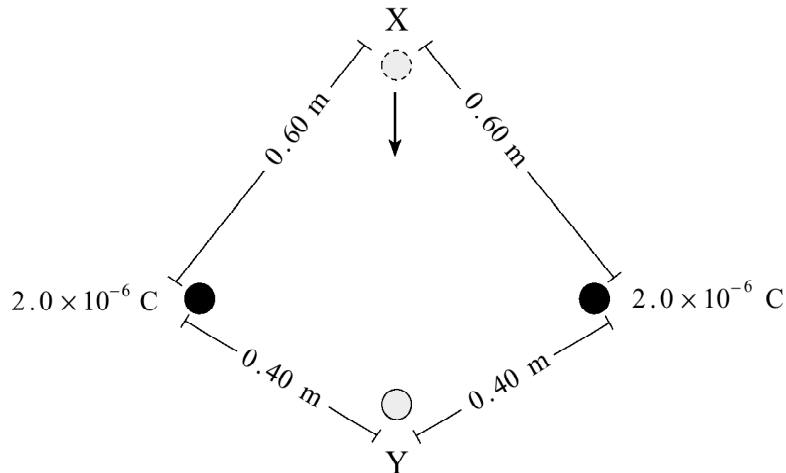

What work must be done to move a 1.2×10^{-7} C charge from location X to location Y?

- A. 3.6×10^{-3} J
- B. 1.5×10^{-2} J
- C. 1.8×10^{-2} J
- D. 3.9×10^{-2} J

47.

Calculate the net electric field (magnitude and direction) at point P due to the two point charges shown in the diagram. **(7 marks)**

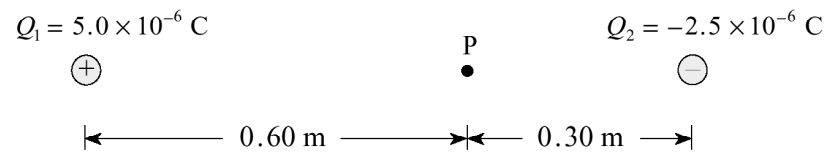

Scholarship Questions (Nasty, but cool!)

9401

48. In one model of the hydrogen atom the electron orbits the proton at a distance of 5.3×10^{-11} m.

- a) Calculate the electric potential energy of this electron. **(3 marks)**
- b) Calculate the kinetic energy of this electron. **(5 marks)**
- c) Calculate the total energy of this electron. **(2 marks)**

9501

49.

Electric charges Q_1 and Q_2 are arranged as shown in the diagram below. Find the electric potential difference, V_{AB} , due to these charges. **(12 marks)**

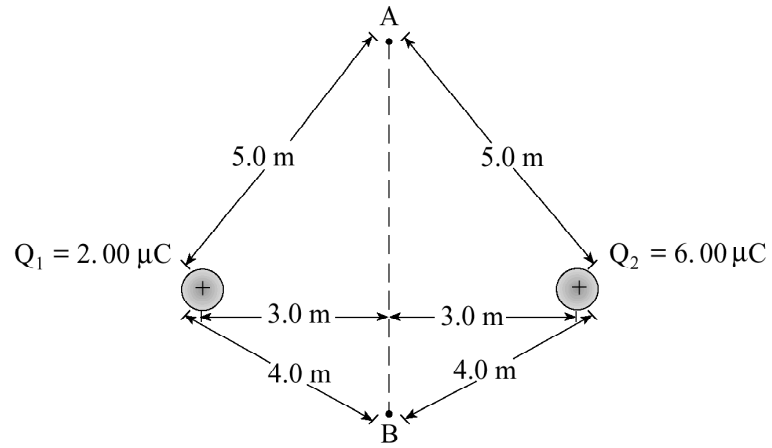

9506

50.

- a) A small sphere carrying 5 excess electrons is suspended between horizontal parallel plates as shown.

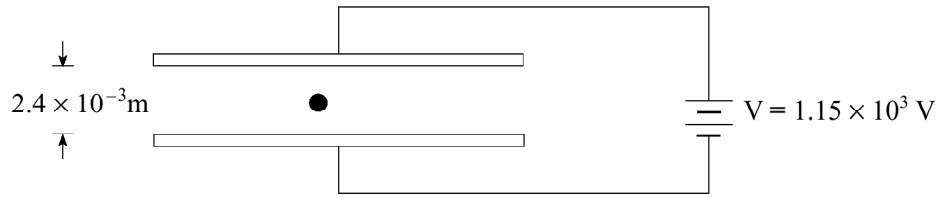

Find the mass of the sphere.

(6 marks)

- b) If the same apparatus is allowed to accelerate downwards in an elevator at 2.7 m/s^2 , what new plate voltage will maintain the sphere's position between the plates?

(6 marks)

9601

51.

A small 4.0×10^{-3} kg charged sphere is suspended by a light thread between parallel plates, as shown in the diagram below. When the plates are connected to a 500 V source, the thread makes a 15° angle with the vertical.

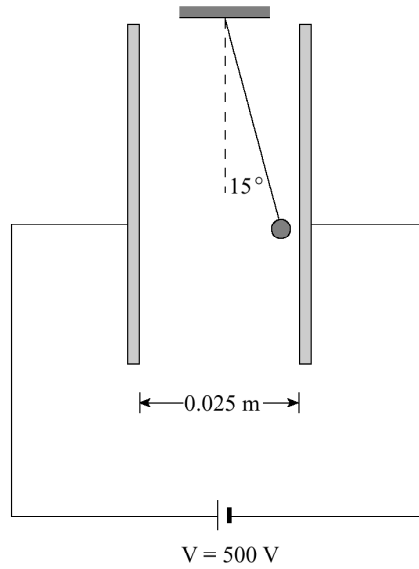

What is the charge on the sphere?

(12 marks)

8906

52.

Two protons are separated by a distance of 1.5×10^{-9} m. If both protons are initially at rest and then one is released, what is the final speed of the released proton with respect to the fixed proton? **(10 marks)**

Answers:

1. d
2. d
3. b
4. a) $v=1.2 \times 10^7$ m/s
b) $F=7.2 \times 10^{-17}$ N
5. d
6. d
7. $V=4.3 \times 10^4$ v
8. see solution key
9. b
10. a
11. a
12. $E=2.3 \times 10^6$ N/c
13. d
14. b
15. b
16. $v=2.0 \times 10^6$ m/s
17. d
18. d
19. c
20. a) 2.4×10^{-15} J
b) $V=1.5 \times 10^4$ v
21. a
22. c
23. c
24. 3.9 J
25. d
26. b
27. b
28. a) $V_B=-27000$ v, $V_A=-45000$ v
b) $\Delta V = 18000$ v
c) $q=+2.0 \times 10^{-6}$ C
29. d
30. c
31. b
32. a) $E=3.2 \times 10^3$ N/c
b) $V=80$ v
c) see key
33. a
34. a
35. a) $E=2.5 \times 10^3$ N/c to left
36. a
37. b
38. c
39. $v=1.2 \times 10^7$ m/s
40. d
41. d
42. oops, I missed #42. Sorry!
43. $Q_1=+7.7 \times 10^{-6}$ C
44. a
45. a
46. a
47. $E=3.8 \times 10^5$ N/c to the right
48. a) -4.35×10^{-18} J
b) 2.7×10^{-18} J
c) -2.17×10^{-18} J
49. $V_{AB}=3.6 \times 10^3$ v
50. a) 3.9×10^{-14} kg
b) 833 v
51. $q=5.3 \times 10^{-7}$ C
52. $v= 1.4 \times 10^4$ m/s